

WKW List Mittermühle- Rechenaufbau 3D

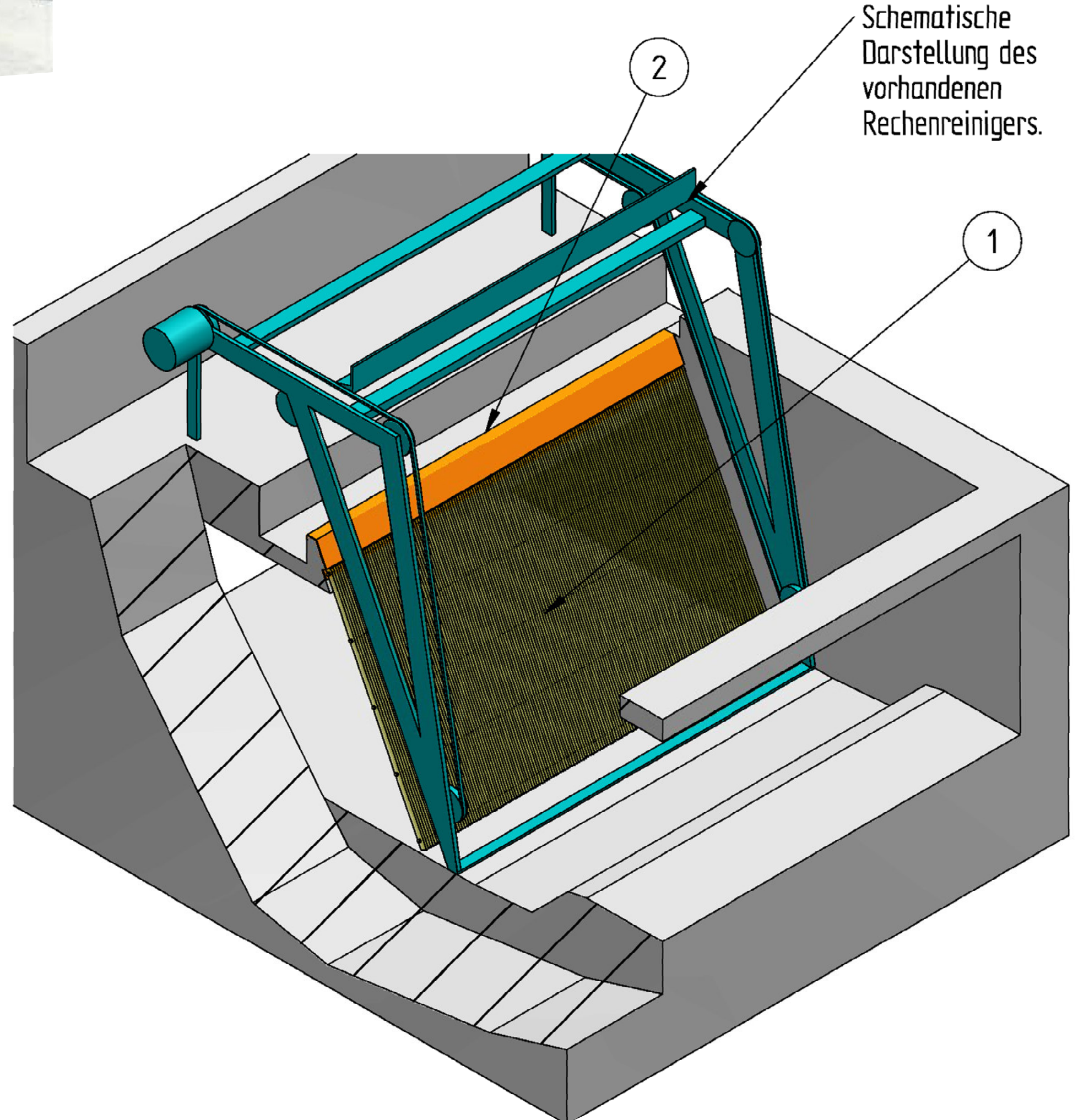

Rechenfeld & Flußrechenstab

1:15

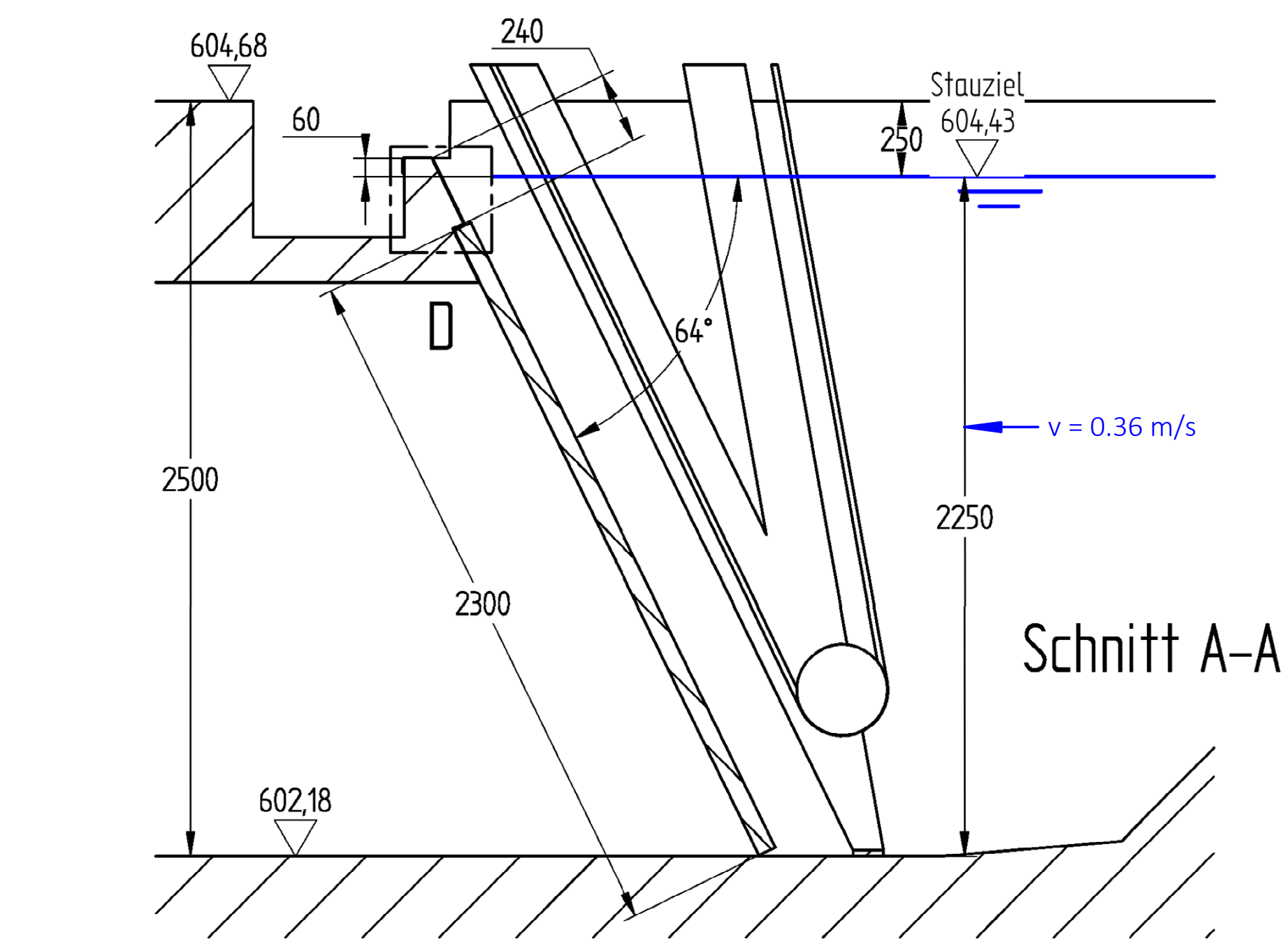
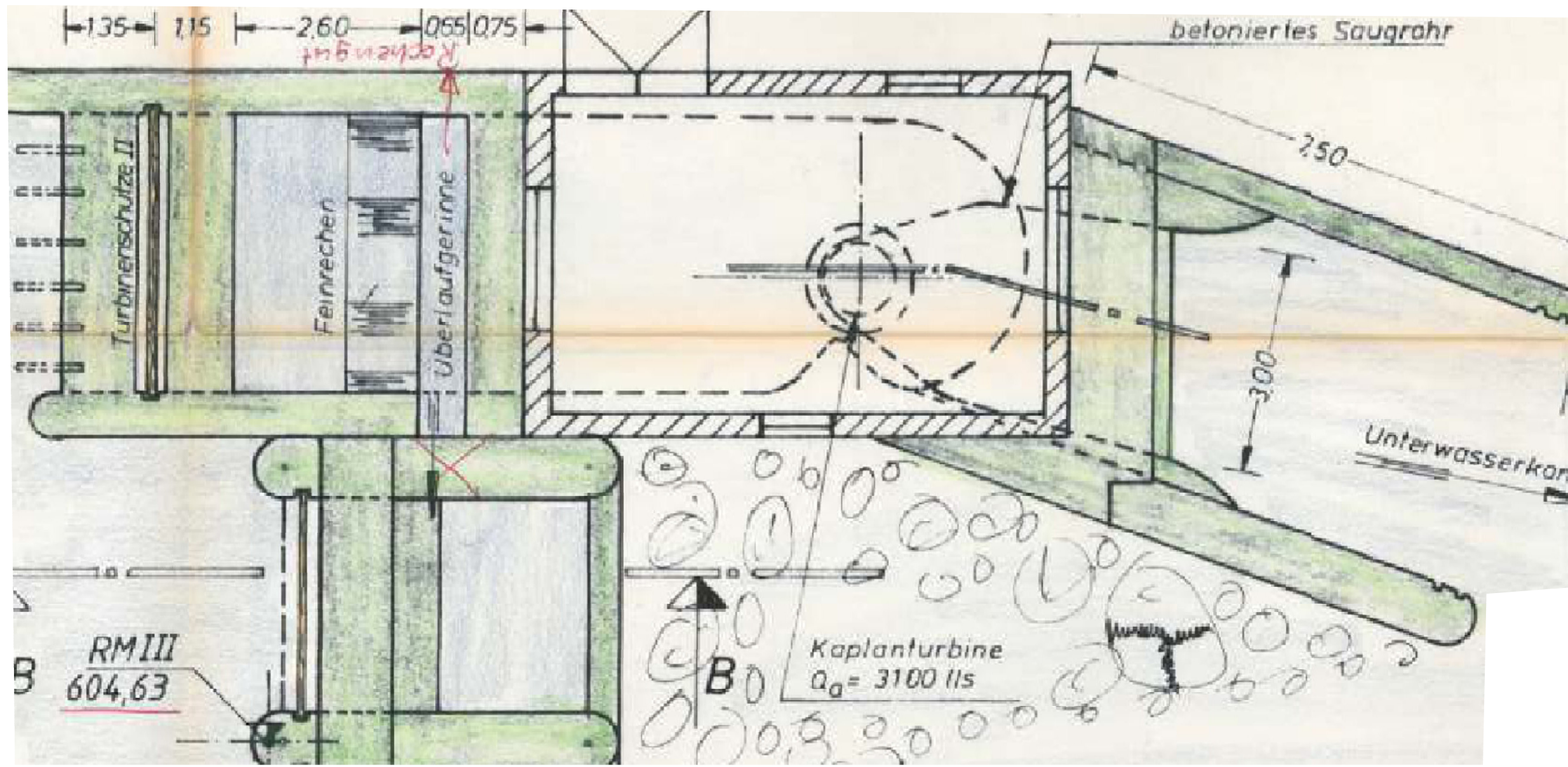
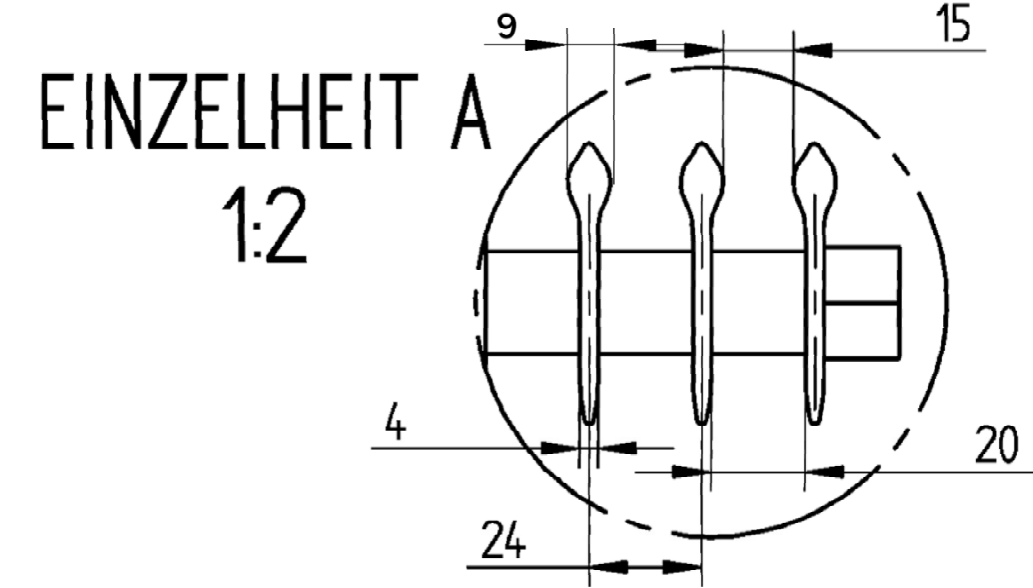
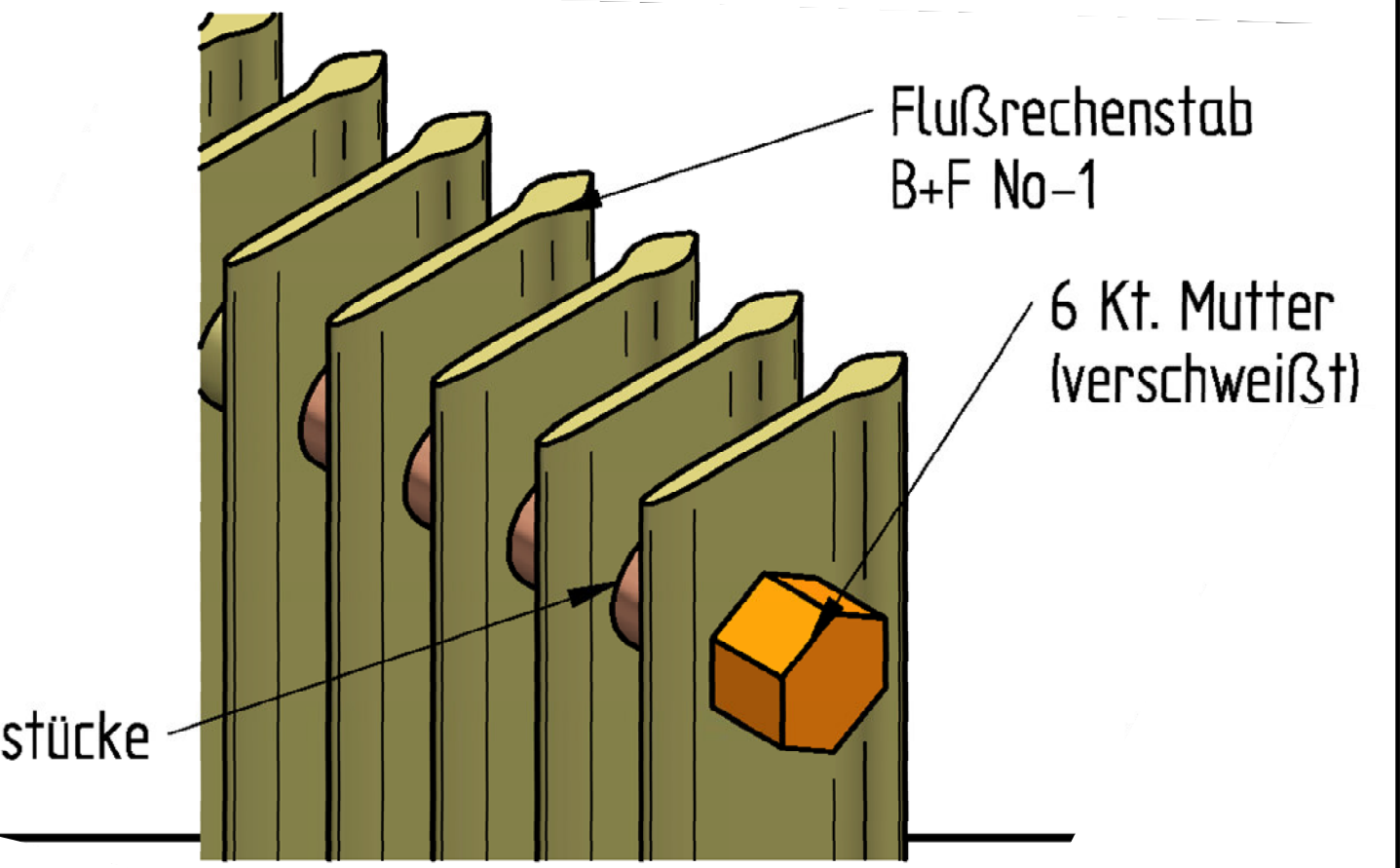
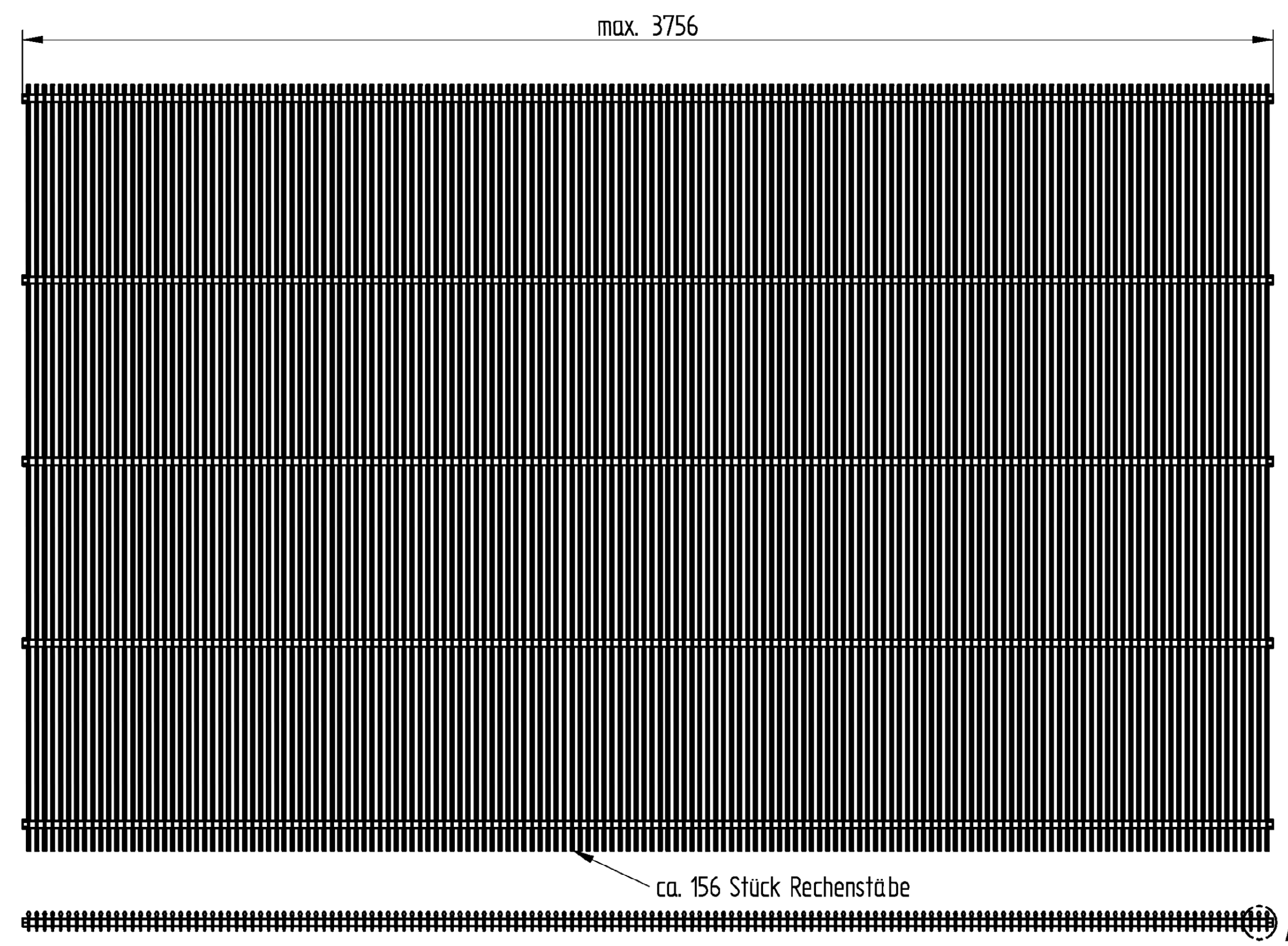

Ing.-Büro Baumgartner Frimhöring 1, 94099 Ruhstorf a. d. Rott Tel: +49 (0) 170 / 588 7546 info@ib-baumgartner.eu		Anhang A4.2	
		Datum	Zeichen
Vorhabensträger: WKW List Mittermühle Mittermühlenweg 16 94078 Freyung		bearbeitet 18.10.2023 MB	gezeichnet geprüf
Bauvorhaben: Wiederbewilligung WKW List Mittermühle am Saussbach / Freyung		M = 1: 15	
Rechenaufbau Rechenfeld	Triebwerk 2		
Entwurfsverfasser: 	Genehmigt:		